

ERTH 101 Final Exam (3 hour) [200 points total]

Fall 2003 Name _____

Short answer questions (give brief answers in a few words):

1. (3) Element P radioactively decays to element D with a half-life of 20 million years. A rock has 5 atoms of P and 70 of D. You may assume that no P or D has been lost from the rock, and that there was no D present initially in the newly formed rock. How old is the rock in years, and what geologic era it is from?

2. (9) Fill in the geologic eras, periods, and epochs on the diagram below. Also indicate the ages of the boundaries between the eras in millions of years, on the left hand side.

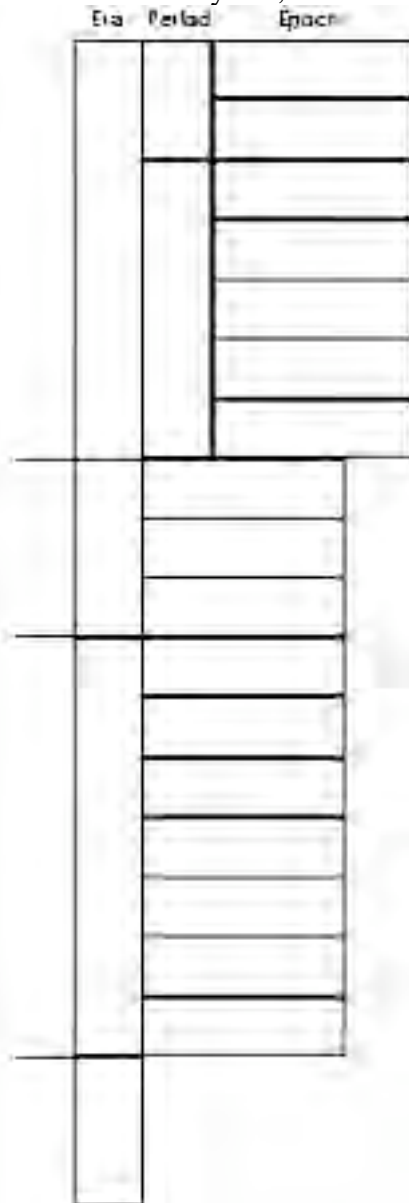

3. **(4)** Explain the principle of uniformitarianism. Why is it fundamental to our interpretations of Earth history?

4. **(3)** Graphite and diamond both have the same chemical composition (C) but differ greatly in hardness, density, and the number of cleavage planes. What term describes two distinct minerals with the same composition? What is responsible for the different physical properties of these two minerals?

5. **(2)** What are the two essential minerals in a gabbro?

6. **(2)** What are the major compositional differences between oceanic and continental crust (use general rock names)?

7. **(3)** What process is responsible for generation of Earth's magnetic field? Within which part of the core or mantle does this occur?

8. **(4)** Provide a sketch illustrating the tectonic setting in which blueschist metamorphic facies rocks occur. Label the position of blueschist rocks on the sketch, and draw an isotherm (constant temperature) to illustrate the temperature distribution.

9. (4) Label the different seismic arrivals in the seismogram below. Which type of wave cannot travel through liquids?



10. (2) Transform faults represent *small circles/great circles* (circle the correct answer).

11. (2) Roughly what fraction of water evaporated from the ocean falls directly back onto the ocean as rain?

12. (3) Weathering of silicate rocks produces dissolved calcium ions, which are carried by rivers into the ocean at a rate of 1.3×10^{13} moles per year. The ocean contains 1.3×10^{19} moles of calcium ions. What is the mean residence time of calcium ions in the ocean? (Assume that there are no other sources of calcium to the ocean.)

13. (2) What is the name of the imaginary line that separates zones of ablation from zones of accumulation on a glacier?

14. (3) List any 3 landforms that provide evidence of past glaciation.

15. (3) Why would a change in the Earth's albedo cause climate to change?

16. **(4)** There are three distinct ways to partially melt a rock. Which of these processes causes melting at mid-ocean ridges? At subduction zones? What types of rocks are produced in each of these settings?

17. **(4)** How are large oceanic plateaus and flood basalt provinces related to mantle plumes?

18. **(3)** What kinds of sediments would you expect to find in a desert environment and what sorts of sedimentary structures might be common?

19. **(3)** What is base level, and how can a change in base level affect the shape of the land surface?

20. **(4)** Explain the sequence of events that lead to the formation of oxbow lakes.

21. **(3)** Why is the climate around 30°N (our latitude here in San Diego) dry? Explain.

22. **(4)** Why are there two tides per day? Explain the forces involved, including the key property of gravity that makes this so, with a sketch.

23. **(4)** What is the Coriolis “force”, and how does it influence the direction of the trade winds?

24. **(3)** What properties of water change in order to drive the thermohaline circulation?

25. **(5)** The continents have an average elevation near sea level, and the oceans have an average depth of about 4 km. Typical oceanic crust is 6 km thick and has a density of 3.0 g cm^{-3} . Assuming that the asthenosphere under both has a density of 3.2 g cm^{-3} , continental crust has a density of 2.7 g cm^{-3} , and seawater has a density of 1.0 g cm^{-3} , how thick is the average continental crust? Assume isostatic equilibrium.

26. **(3)** How does carbon dioxide get added to the ocean-atmosphere system on geological timescales?

27. (4) Describe the formation of coal, and the four stages it goes through.

28. (3) In what plate-tectonic setting would you expect to find “mounds” of precipitated sulfide minerals, including iron, copper, and zinc?

29. (5) On the block diagram below, the black rectangles show parts of outcrops of a dike that dips 45° to the north. On the diagram and the map view below it, sketch the complete outcrop pattern of this dike. The stream flows to the south.

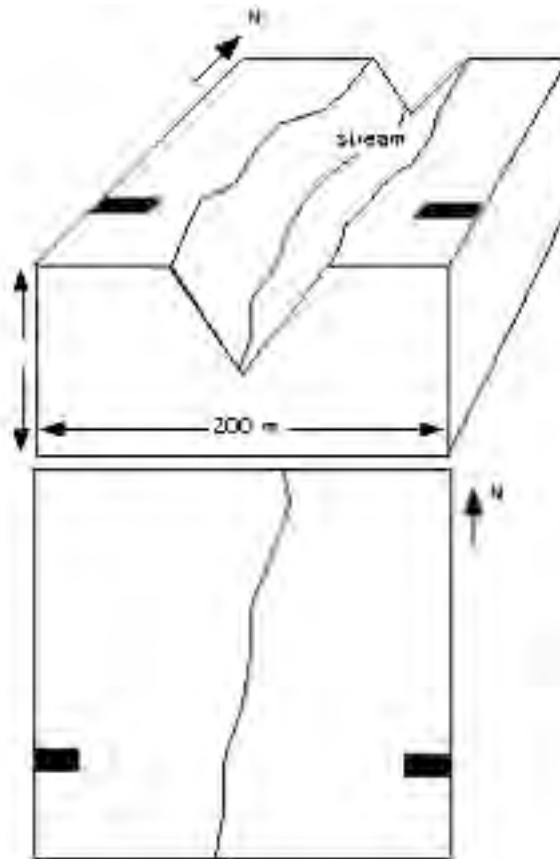

← MAP VIEW

33. **(8)** Explain in detail how seafloor magnetic anomalies were key in the acceptance of the theory of plate tectonics. Indicate how magnetic anomalies formed.

34. **(8)** This question requires some integration of what you have learned, to address a problem that is unfamiliar. If seafloor spreading rates were halved, then held at this low level for hundreds of millions of years, what would happen to Earth's climate and why? How would the decreased spreading rate affect sea level and why?

35. **(6)** Illustrate with a sketch the evidence that the outer core is liquid. Use specific numerical values. What is the evidence that it is made of iron?

36. (6) What characteristics distinguish the inner planets from the outer planets? How did these differences arise?

37. (4) When did atmospheric molecular oxygen (O_2) first become abundant, and what sedimentary rock formation provides evidence for this date?

38. (6) For each atom of carbon buried and preserved as organic matter, one molecule of oxygen is emitted to the atmosphere. Why then is the total amount of buried organic matter (which is mostly in shales) about 30 times the amount of atmospheric oxygen today, on a mole-for-mole basis?

39. (4) Why are there no Precambrian coal deposits?

40. (6) A new planet has been discovered and we would like to know whether plate tectonics is occurring on this planet. What types of evidence should we look for? Keep in mind that we only have remote sensing.

41. **(9)** Many of the characteristics of a section of oceanic crust are developed within the central few kilometers of the spreading center at which it is created. Sketch a cross-section of a mid-ocean ridge from the axis out to a few tens of kilometers. Illustrate the relative depth of the seafloor, the nature of the upper mantle (lithosphere and asthenosphere), and the crustal layers. Indicate whether your drawing is typical of a fast or slow spreading ridge axis. Below the sketch, *briefly* explain the processes (for example, melting, extrusion, faulting, and hydrothermal activity) that occur in the various parts of the system.

42. **(8)** How do the Earth's continental crust, oceanic crust, mantle, and core differ in composition? (use rock names) Explain why this difference occurs.

43. **(6)** Describe the sequence of events leading to the formation of economically viable oil deposits. Include the environment of formation as well as the tectonic and stratigraphic conditions that allow such deposits to accumulate. Why is oil less than one-fifth as abundant as coal?

44. **(10)** Sketch and label a cross-section to the center of the Earth with layers based on composition, physical properties, and seismic velocity. Sketch curves of approximate S and P wave velocities. Your sketch need not be to scale, but please draw and label clearly. Be sure to include the depth of the bottom of each layer. Include lithosphere, crust, asthenosphere, mantle, mesosphere, moho, low velocity zone, inner core, outer core.